

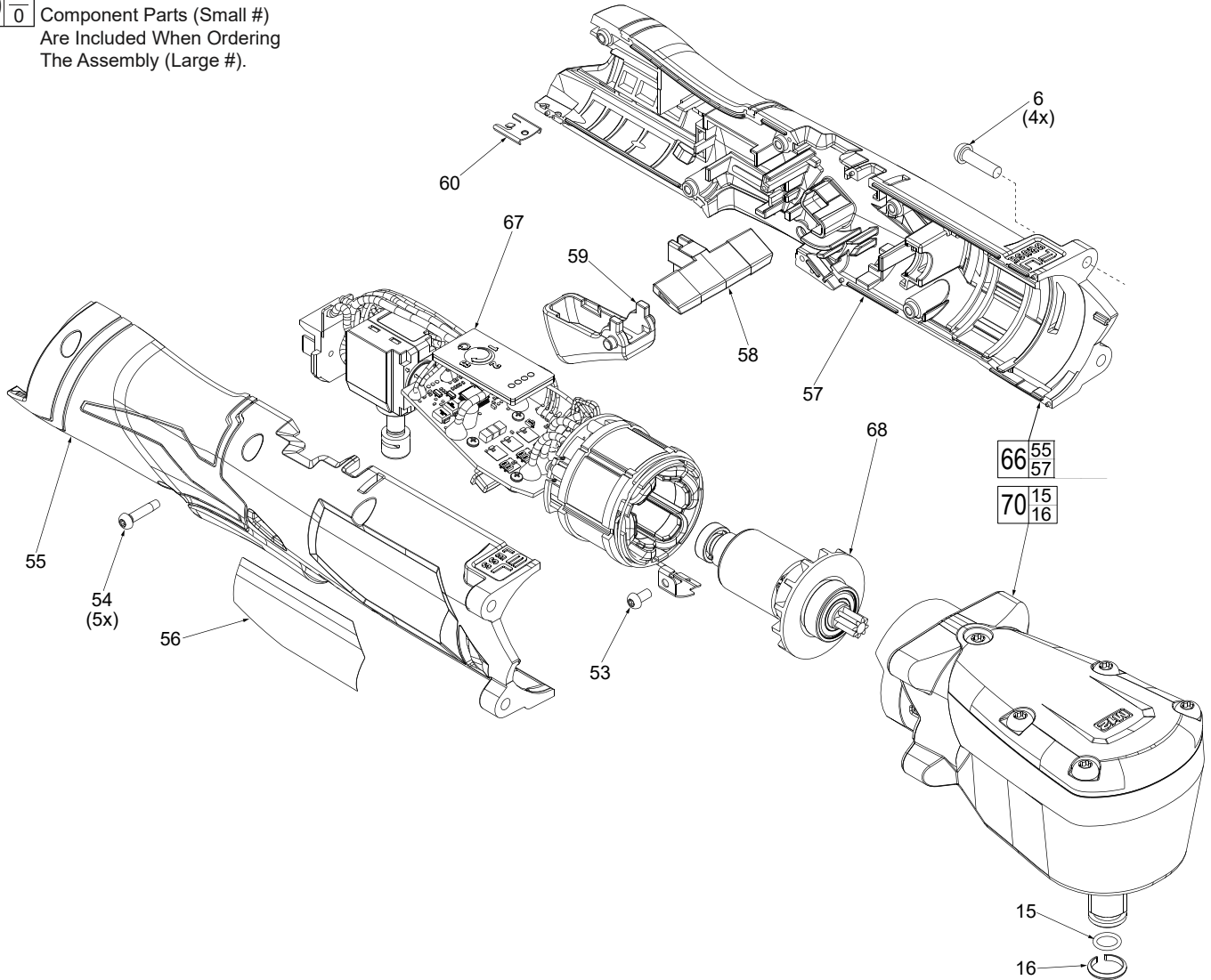

SERVICE PARTS LIST

SPECIFY CATALOG NO. AND SERIAL NO. WHEN ORDERING PARTS		REVISED BULLETIN	DATE
M12™ FUEL™ 1/2" Right Angle Impact Wrench w/ Friction Ring			Jan. 2020
MODEL NO. M12FRAWIF12-0	2565-20	WIRING INSTRUCTION See Page 2	

EXAMPLE:
 Component Parts (Small #)
 Are Included When Ordering
 The Assembly (Large #).



SCREW TORQUE SPECIFICATIONS

FIG.	WHERE USED	SEAT TORQUE	
		(KG/CM)	(IN/LBS)
6	Housing/Gearcase	21±1	18±1
53	Ground Plate	10±1	8±1
54	Housing Cover	10±1	8±1

WIRING INSTRUCTIONS

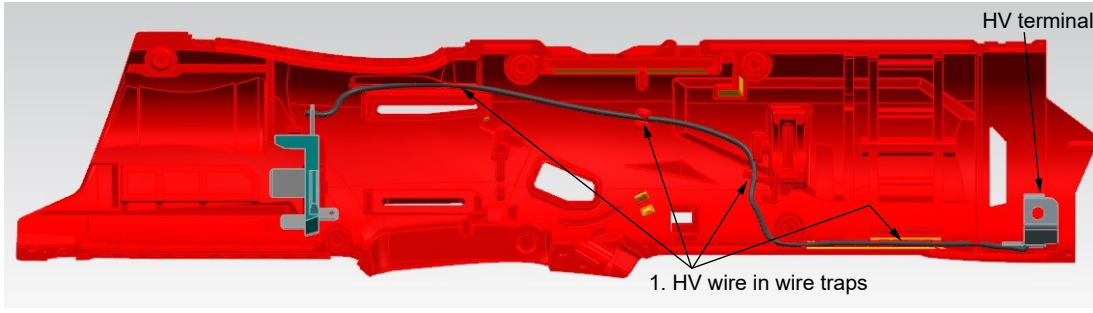

1. HV wire in wire traps

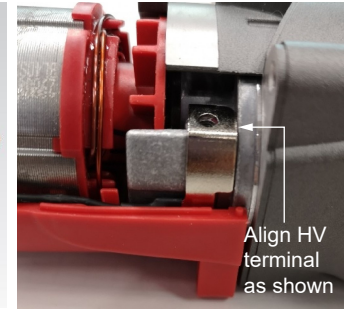

Align HV terminal as shown

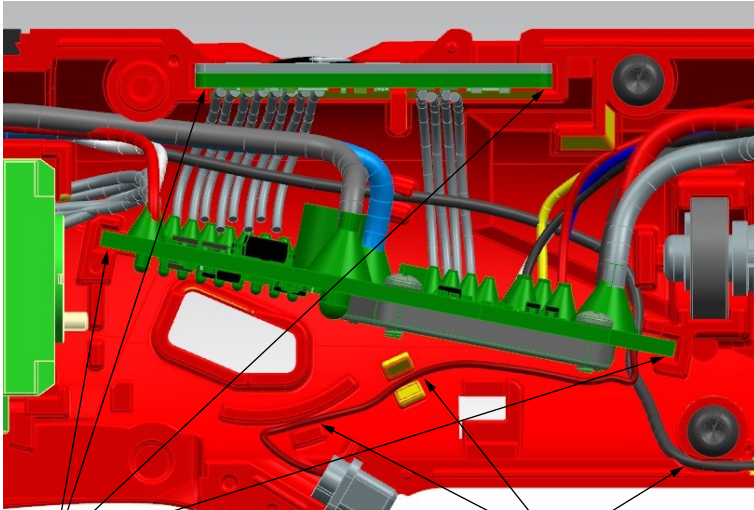

2. Seat PCBA in recesses

3. Place wires in traps

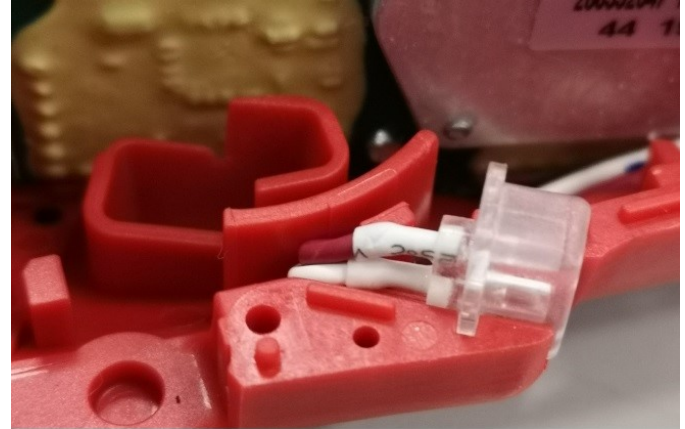

4. Place LED light in recess with the red wire to the top

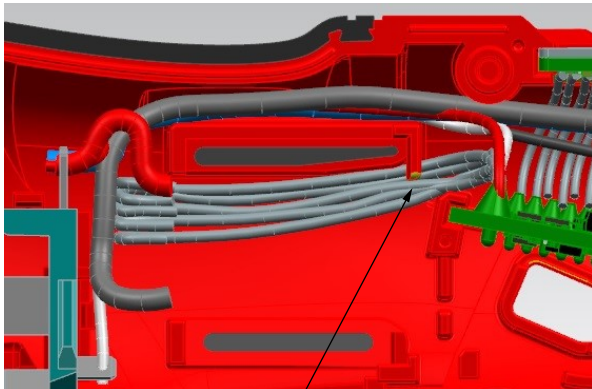

5. Route cable through this groove

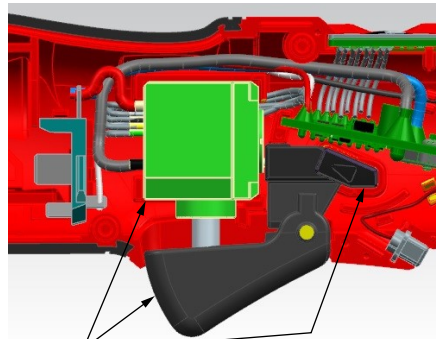

6. Place switch, forward/reverse shuttle and trigger in handle support recesses as shown

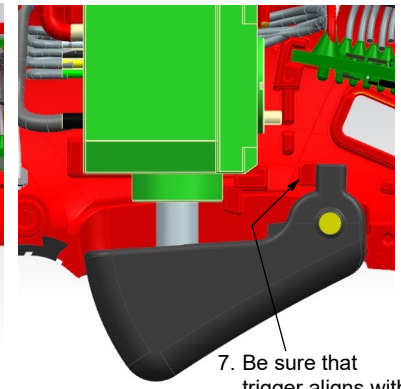

7. Be sure that trigger aligns with rib as shown

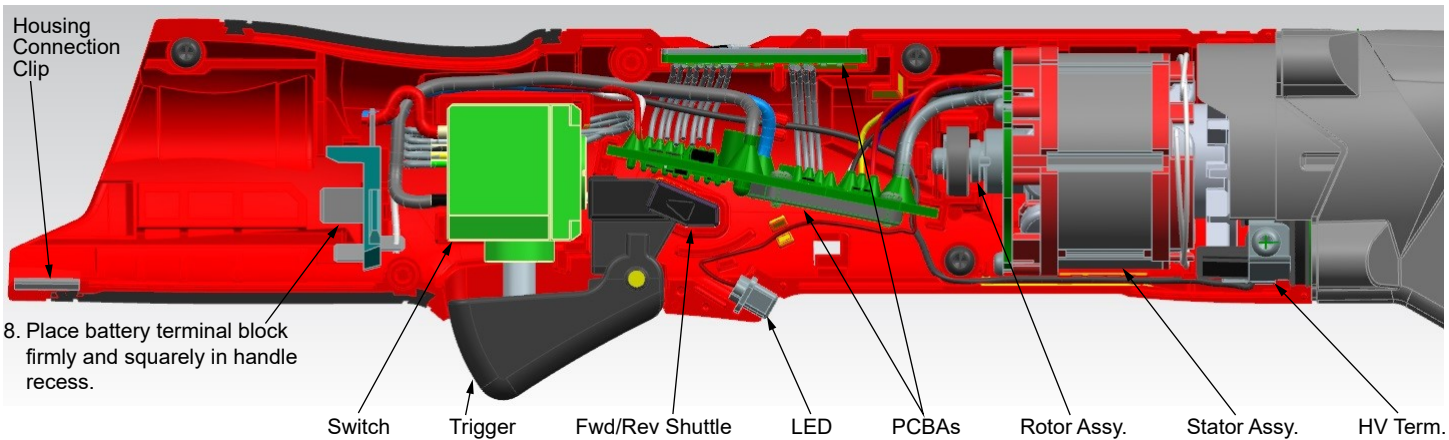

8. Place battery terminal block firmly and squarely in handle recess.

Switch Trigger Fwd/Rev Shuttle LED PCBAs Rotor Assy. Stator Assy. HV Term.

Prior to installing the Housing Cover, be sure all elements of the Electronics Assembly are seated properly (Stator, Main PCBA, Selector PCBA, On-Off Switch, LED Assembly and Battery Terminal Block Connector). Be sure the Grounding Terminal is in place and that all wires are pressed down into all wire traps and channels. Check to assure that

wires will not interfere with moving parts. Prior to installing the Housing Cover, place Forward/Reverse Shuttle onto On-Off Switch and through Housing Support opening. Check to assure that wires will not be pinched. Secure the Housing Cover to the Housing Support with five M3 x 16mm ST T-10 Screws. Be sure to replace the Housing Clip at the bottom of the battery opening.